

Outstanding Shotcrete Project Award Winner

2005 Outstanding Underground Project:

The Center for National Response

by Henry A. Russell, Jr.

In 1953, the Memorial Tunnel in Standard, WV, was constructed as a two-lane, 2800 ft (853 m) tunnel with semi-transverse ventilation. The owner operated the tunnel until the mid-1980s when a four-lane bypass was constructed to upgrade the West Virginia Turnpike to current interstate standards. The tunnel was abandoned until 1989 when the Federal Highway Administration (FHWA), in conjunction with the American Society of Heating, Refrigerating, and Air-Conditioning Engineers (ASHRAE), using the Central Artery Project for the funding, instituted the Memorial Tunnel Fire Ventilation Test Program. The test program consisted of performing controlled test fires up to 100 megawatts to provide valuable information for ceiling wall partition design, the protection of facilities for power ventilation and lighting, and the evaluation of methods to properly control the ventilation of a tunnel under various fire scenarios. Parsons Brinckerhoff Quade & Douglas, Inc. (PB), was retained to perform the test program. As part of the test program, an evaluation of the structural condition was performed and structural repairs were designed. A critical part of the design was to insulate structural portions of the tunnel for temperatures in excess of 2000 °F (1093 °C).

The rehabilitation program for the reuse of the tunnel required sealing all cracks in the tunnel liner because the bedrock around the tunnel contained low-flashpoint cannel coal. In addition to the sealing of the cracks, extensive structural rehabilitation of the liner was performed to repair damage from the excavation of the bypass for the highway. Numerous products were evaluated to provide suitable fire protection for the structural elements of the ceiling and for mechanical equipment anchorages. The test program included the use of traditional ventilation with a tunnel ceiling and tests with the ceiling removed for the use of jet fans. The construction contract for the rehabilitation of the tunnel and the removal of the ceiling had a construction cost of \$10 million. During the test program of 98 fires, routine inspections of the tunnel were performed to evaluate the performance of the structure fireproofing. Based on the performance of certain structural elements, changes were made in the use of structural fireproofing and code requirements for the protection of equipment. After the test program in 1991, the tunnel was again abandoned. This work was performed by PB and managed by Henry Russell, Jr. (Many of the lessons learned during this test



East portal of the Center for National Response (Memorial Tunnel)



Collapsed tunnel training area

Outstanding Shotcrete Project Award Winner

program were included in the current International Tunneling Association [ITA] document on “Guidelines for Structural Fire Resistance for Road Tunnels.”)

In 2000, The Department of Defense (DOD) expressed an interest in establishing a training site for counterterrorism management and training. The Memorial Tunnel was again considered for the site of a training facility. Titan Corporation was retained as the facility operator with PB being the Engineer of Record for the rehabilitation of the tunnel. PB was retained to assist the operator in maintaining the structure and design of the training mockups.

Today the Center for National Response serves as a training facility for first responders, local fire and rescue departments, police, federal agencies, and the DOD. The training center is used for counterterrorism training related to hazardous materials, highway, transit, and all underground structures, including related explosive and collapse incidents.

Tunnel Description

Memorial Tunnel is a concrete-lined rock tunnel with a reinforced cast-in-place concrete liner, constructed in the mid-1950s. The tunnel was constructed in sedimentary bedrock with numerous coal seams. The bedrock is variable in strength and has extensive vertical and horizontal jointing. As a result of the variable conditions, the mining of the tunnel was difficult; in numerous locations, steel ribs and lagging were used to maintain the excavation until the cast-in-place concrete liner was installed.

The tunnel is a typical two-lane bidirectional tunnel with semi-transverse ventilation. The ventilation ducts were located above the roadway in the tunnel arch and were separated from the roadway by a 6-in. thick (152 mm) reinforced concrete ceiling. This ceiling was supported at the centerline of the tunnel and is keyed into the concrete side walls of the tunnel. The vertical clearance of the original roadway was 14.5 ft (4.4 m). The tunnel is approximately 2800 ft (854 m) long from portal to portal, slopes at a 6% grade from north to south portal, and is approximately 29 ft (8.76 m) in width. Each portal has a two-story ventilation building situated over the tunnel entrance.

In the 1980s, the tunnel was rehabilitated for use as a test site for the operation of ventilation equipment for emergency use as part of the Central Artery Project. This rehabilitation required extensive concrete restoration and structural modifications to the tunnel. The most notable of



Subway section training area



Counterterrorism training



Highway incident training area

Outstanding Shotcrete Project Award Winner



Typical tunnel cross section

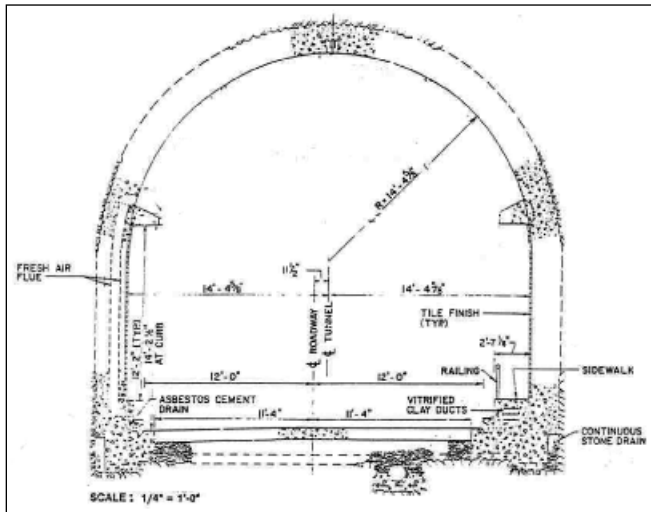

Typical existing tunnel section



Deep concrete spall in liner

Typical structural damage from fire tests

these was the elimination of the tunnel ceiling, which changed the configuration of the tunnel to an open-arch tunnel with high vertical walls. The current vertical clearance of the tunnel is approximately 26 ft (7.82 m) from the base slab to the arch crown.

The interior of the tunnel has a concrete slab-on-ground with steel edge curbs on both sides. The northbound lane of the tunnel has a 3 ft-wide (915 mm) walkway that was used for emergency exit. This walkway is approximately 3 ft (915 mm) above the roadway slab. The curbs are constructed to provide for a continuous gutter drain on each side of the tunnel. The roadway's cast-in-place concrete slab was modified during the fire ventilation testing operation. In the southbound lane, a portion of the slab was removed creating a utility trough the entire length of the tunnel. Six-inch thick (152 mm) precast concrete panels cover the trough.

Lighting for the tunnel is attached to the tunnel walls with surface-mounted electrical conduits. Currently, there is no operating ventilation or fire suppression system in the tunnel.

Rehabilitation Program

PB performed an in-depth condition survey; based on that survey, a prioritization of repairs was made to allow for the structural rehabilitation of the tunnel. It was noted during the inspection that the tunnel liner had been damaged as a result of the fire tests.

Existing Conditions

The tunnel defects consisted of spalls, delaminations, and severe cracks. Many of the cracks in the cast-in-place tunnel liner allow the intrusion of groundwater that, over time, will create delaminations and spalling of the tunnel liner.

Tunnel Arch

The tunnel arch for the entire length of the tunnel is subject to groundwater intrusion at numerous construction joints and cracks and at the interface of the portal building and the tunnel headwalls. As a result of the intense heat from the fire tests, the construction joints have, in most cases, lost their ability to seal the joint. It appears that the bitumen used for the waterproofing has melted out of the joint or was incinerated. In many cases, the leaking concrete cracks are random in nature and are either a result of concrete shrinkage, settlement or movement, or thermal movement during the fire test program. These leaking construction joints and open leaking cracks must

Outstanding Shotcrete Project Award Winner

be sealed to prevent the further deterioration of the structural liner.

At Station 14+50 northerly for a distance of 180 ft (55 m) on the west side of the tunnel arch, there exists a series of parallel longitudinal cracks that parallel the centerline of the tunnel. The presence of close parallel horizontal cracks at an orientation parallel to the centerline of the tunnel arch create a potential for the tunnel to have part of the liner fall into the tunnel and cause a failure of the arch. These cracks present a stability problem for the arch and must be sealed and reinforced with a structural overlay of a fiber-reinforced cementitious mortar to reinstate the stability of the arch.

During the test program, a fire pot was installed in the tunnel, affecting approximately 400 linear ft (122 m) of tunnel arch that has severe spalling and delamination due to the intense heat of the tests. In these areas, the tunnel arch has undergone severe stress as a result of the thermal activity, and the ultimate strength of the concrete is in question. The loss of cross section of concrete in the arch places unusual load on bedrock, which is one of the areas that required additional support during construction. The reinforcement that was exposed has not buckled or failed. This spalling has occurred in two distinct areas and must be repaired to maintain the long-term structural integrity of the tunnel. The best method to reinstate the tunnel lining in the arch is to apply wet-process shotcrete using fibers to provide additional strength. New reinforcing steel is also required and, in combination, will provide for a suitable long-term monolithic repair.

Structural Repairs to the Concrete Tunnel Lining

Based on PB's experience, the most effective, rapid method of repairing the structural liner is to restore the concrete arch to its original lines by using dry-process shotcrete. Dry-process shotcrete



Typical leaking crack in tunnel arch



Station 14+50—horizontal cracking of arch

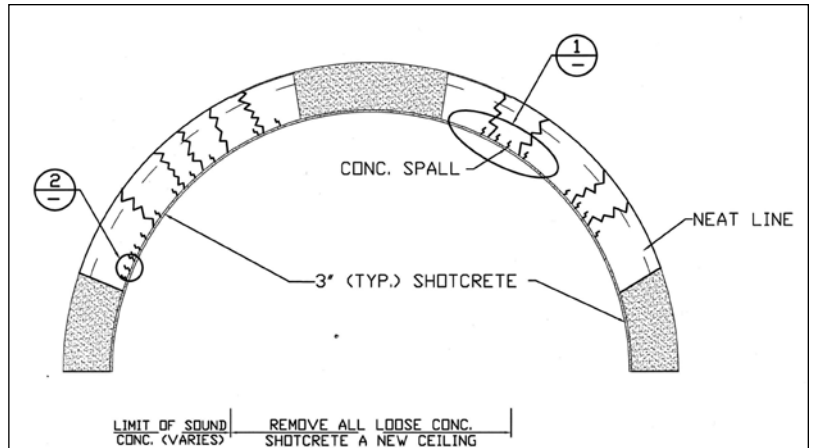

Typical tunnel liner shotcrete bands

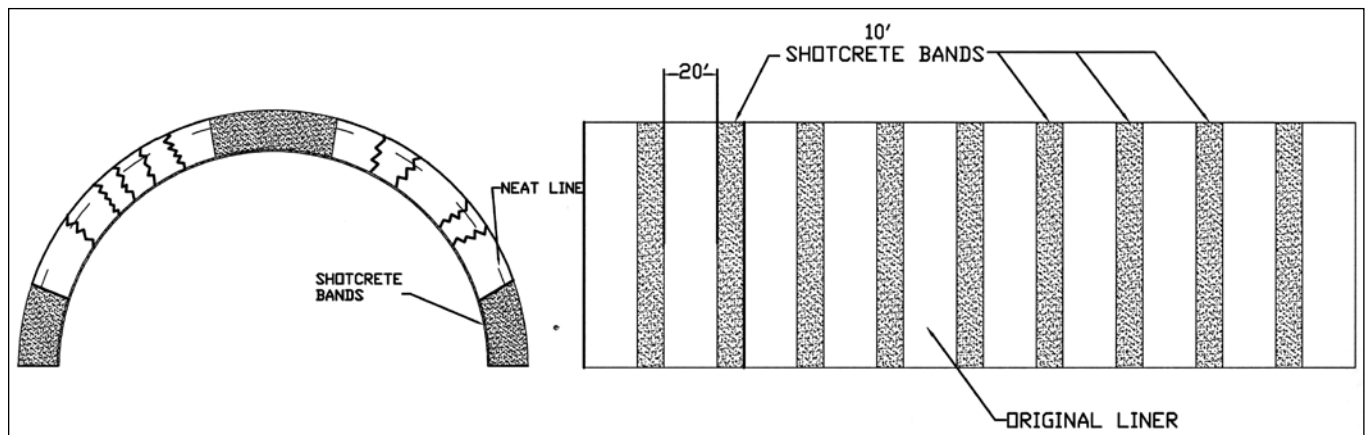

Layout of tunnel liner shotcrete bands

Outstanding Shotcrete Project Award Winner

is a process of applying prepackaged fiber-reinforced fly-ash-modified mortar by pneumatic means. The material, prepackaged by the manufacturer to ensure proper proportions and quality control, is moistened on site and applied by a dry-process shotcrete method. The areas to be repaired are prepared by power washing to remove any laitance, and a wire mesh is mechanically attached to the substrate prior to the application of the shotcrete. Any leaking concrete cracks or construction joints must be sealed prior to the application of the shotcrete; otherwise, the shotcrete will not bond properly to the substrate.

The application of this shrinkage-compensated fiber-reinforced material provided a durable, sound monolithic repair. The application was chosen due to the project time restraints, as the process is rapid with minimal overspray or rebound, resulting in minimal cleanup.

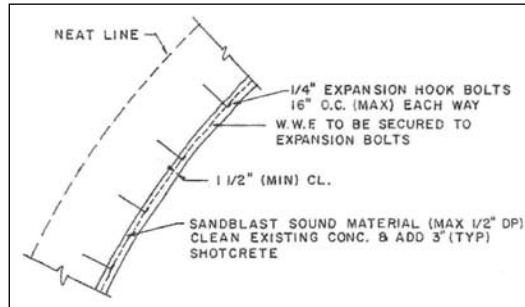

Detail for concrete arch repair

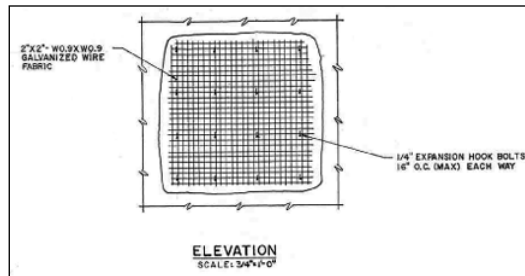

Typical shotcrete repairs



Typical spalled area for repair with welded wire installed

The concrete arch cracking required the structural integrity of the arch to be restored. This required placing a series of reinforced shotcrete bands on the interior of the tunnel liner form springline to springline of the arch to transfer the compression load of the arch to the vertical walls of the tunnel.

Sealing of Concrete Cracks and Construction Joints

The sealing of leaking concrete cracks and construction joints was to prevent the infiltration of groundwater and may be performed by the injection of chemical grout. Chemical grout is the preferred product to seal leaking concrete cracks. The injection of chemical grout into the leaking crack is performed by a single-component water-reactive polyurethane chemical grout. The installation is performed by the drilling of angle holes into the repair area at a high angle to intersect the crack at the midpoint of the wall. Injection ports are installed and the ports are flushed with fresh water. This flushing removes any laitance in the crack and provides a catalyst to react the chemical grout. The injection of the polyurethane grout is performed working from one end of the crack to the other, observing the return of the grout on the concrete surface. This process provides full-depth penetration of the cracks, is flexible, and has the ability to move with the crack as a result of thermal expansion.

The tunnel, as a result of the extensive fire testing, had structural changes made to the configuration, the structural liner, and the ventilation buildings. An in-depth condition survey was performed, and based on that survey, a prioritization of repairs was made to allow for the structural rehabilitation of the tunnel. It was noted during the inspection that the tunnel liner had been damaged as a result of the fire tests.

Late in 2000, the operator went into an extensive training program that required full use of the tunnel for training purposes. After September 11, 2001, the center was required to operate extensive training programs that necessitated our development of a structural repair program that would not adversely impact the training operations.

The rehabilitation program required over 3600 ft³ (102 m³) of a polymer-modified, fiber-reinforced, shrinkage-compensated shotcrete to be applied on the interior of the tunnel to reestablish the structural support for the tunnel arch. In addition, over 1700 linear ft (518 m) of crack sealing for groundwater control and waterproofing of the tunnel's north portal area was performed.

Outstanding Shotcrete Project Award Winner



Typical chemical grout injection for tunnel joints



Dry-process shotcrete machine with premoistener

In November 2003, a construction contract was developed to perform the structural repairs. This contract required the work to be performed in a 3-week period in January 2004 to maintain the DOD training schedule. The bidders were selected by PB based on experience and qualifications.

The successful bidder was Coastal Gunitite Construction Company of Baltimore, MD. US Concrete Products of Linthicum, MD, manufactured the special prepackaged shotcrete as well as the cementitious waterproofing. DeNeef Construction Chemicals was selected to supply the material for groundwater control. Extremely close coordination was required to have the total amount of shotcrete and chemical grout on site on January 2, 2004. This coordination required rapid submittal, approval, and turnaround of shop drawings and an all-out manufacturing effort on the part of the materials suppliers to have the material on site on time. The work was started on January 3, 2004, and completed within 2 weeks—a week ahead of schedule—and turned over to the operator within the time frame specified.

The shotcrete was applied using a standard dry-process shotcrete machine with a premoistener to minimize dust. The work was generally performed from a man lift with the shotcrete machine on the roadway. The prepackaged shotcrete was delivered in super sacks to facilitate production.

This project is unique because this underground space had three separate uses after being abandoned twice. The last rehabilitation required a fast-track effort between the owner, operator, design engineer, manufacturers, and contractor to provide a successful project on time and within budget. The cooperation between all parties was exceptional and a vital element of our Homeland Security was maintained with no impact on the training. The value of the project was approximately \$600,000.

Outstanding Underground Project

Project Name

The Center for National Response
(Memorial Tunnel)

Location

Standard, WV

Owner

The Department of Defense
(West Virginia National Guard)

Operator

Titan Corporation

Project Engineer

Parsons Brinckerhoff Quade & Douglas, Inc.

Project Manager

Henry A. Russell, Jr., PE



Henry A. Russell, Jr., PE, is a Vice President, Principal Professional Associate of Parsons Brinckerhoff Quade & Douglas, Inc. Russell is also Chair of the International Tunneling

Association's Working Group 6 Repair and Maintenance of Underground Structures. He is a member of the Moles and has over 35 years of experience in the design and rehabilitation of underground structures in the U.S. and overseas. He has authored over 30 professional papers. His project on the "Rehabilitation of the Center for National Response" received the American Shotcrete Association Outstanding (Underground) Shotcrete Project Award for 2005.