

Steel Fibrous Shotcrete: A Summary of the State-of-the-Art

by Charles H. Henager

This report describes the technology and uses of steel fiber-reinforced shotcrete, a material containing up to 2 percent by volume of steel fibers. The fibers are on the order of 1 in. long by 0.016 in. diameter (25 mm x 0.4 mm). Mechanical properties, particularly ductility, toughness, and flexural strength are improved by the fiber addition and these improvements are described along with other typical properties and proportions of typical mixes. Batching and mixing methods and application procedures are described, including methods of reducing rebound, special equipment developed for applying fibrous shotcrete, and modifications used with conventional equipment. Applications of steel fibrous shotcrete in the U.S., Europe, and Scandinavian countries are described. These include rock slope stabilization work, construction and repair of mine and tunnel linings, and bridge arch strengthening. In applications where the fibers can be used to replace steel mesh, the material has resulted in savings in construction time and cost.

Keywords: fiber reinforced concretes; fibers; linings; metal fibers; mines (excavations); mix proportioning; placing; reviews, shotcrete; slope protection; stabilization; strength; subsurface structures; tunnel linings.

Reproduced with permission from the January 1981 edition of Concrete International—the magazine of the American Concrete Institute.

Introduction and summary

Steel fibrous shotcrete has been used for mine and tunnel linings, for rock slope stabilization, in dam construction, for repair of deteriorated surfaces and arches, for fire protection coatings, and in thin shell dome construction. This relatively new material, which incorporates up to 2 percent by volume of steel fibers on the order of 1 in. long x 0.016 in. in diameter (25 mm x 4 mm), has much improved ductility and toughness over plain shotcrete. Flexural strength is increased on the order of 50 percent to 100 percent and compressive strength may be improved up to 50 percent. Improvements in toughness and impact resistance are on the order of a factor of 10 or more.

Application of steel fibrous shotcrete is routinely done using existing equipment with little or no modifications. Mixing and placing equipment are available from manufacturers worldwide. Several items of equipment designed especially for metering and dispensing steel fibers are available.

Investigation of factors affecting rebound has shown that the most effective measures to reduce material rebound are to reduce the air pressure (air velocity or amount of air at the nozzle), to use higher percentages of fines, to use shorter fibers, to predampen (if necessary) to get the right moisture content, and to shoot the mix at the wettest stable consistency.

Shotcrete Classics

Steel fibrous shotcrete — general

Steel fibrous shotcrete was first placed in the United States early in 1971 in experimental work under the direction of D. R. Lankard of Battelle's Columbus Laboratories.⁽⁸⁾ Additional trials were made under the direction of M. E. Poad for the U.S. Bureau of Mines in cooperation with the author in an investigation of new and improved methods of using shotcrete for underground support.⁽¹³⁾ Subsequently, R. A. Kaden of the U.S. Corps of Engineers supervised the first practical application of steel fibrous shotcrete in a tunnel adit at Ririe Dam, Idaho, in 1973.⁽²⁾ Since that time, there have been numerous applications and research investigations, some of which are described in this report. Steel fibrous shotcrete has also been placed in Germany (Stahlfaserspritzbeton), Sweden (Stalfiberarmerad Sprubeton), England, Norway, Finland, Switzerland, Poland, South Africa, Australia, Canada, and Japan.

The inclusion of steel fibers in shotcrete improves many of the properties of the basic material. The toughness, impact resistance, shear strength, flexural strength, durability factor, and the fatigue endurance limit are especially improved. An important improvement is evident in the mode of failure; large deformations are required to cause failure and the material continues to carry a significant load after cracking. This property has been cited as providing a measure of ductility to the concrete.^(9,12,14) A large increase in the strain-to-failure provides post-crack resistance which is an advantage in applications such as tunnel and mine linings where there may be relatively large deformations. Patents on the material

are held by the Battelle Development Corporation, Columbus, Ohio, which has trademarked the material Wirand[®] concrete.

Mix compositions and strength

General

Most steel fibrous shotcrete placed to date has used the dry process. Early placements used a fine aggregate mix having a sand:cement ratio of 2.4:1 by weight or about 940 lbs. of cement per yd³. This is called the "standard mortar mix" when used for cast-in-place applications. Mixes containing 3/8 in. (9 mm) and 3/4 in. (19 mm) aggregate and less cement have been used more recently. The fiber sizes have varied from 1/2 in. to 1 1/2 in. (13 mm to 38 mm) long and from 0.010 in. to 0.020 in. (0.25 mm to 0.51 mm) in diameter. The amount of fiber has varied from about 0.5 percent by volume to about 2 percent by volume. The proportions of typical mixes are shown in Table 1. The fiber amounts shown in Table 1 are before shooting. Since the fiber rebound is generally greater than the aggregate rebound, there is usually a smaller percentage of fiber in the material on the wall.⁽⁹⁾ Sand weight shown is moist weight with about 5 percent moisture.

Fibers

Fibers are manufactured by at least three processes: 1) by cutting cold-drawn wire, 2) by slitting steel sheet, and 3) by extracting them from a pool of molten steel (called melt-extraction). Carbon steel fibers are used in applications at ordinary temperatures. Stainless steel fibers are used in high temperature and refractory concrete applications. Wire



Fig. 1: Brick railway bridge near Birmingham, England, reinforced with about 6 in. (150 mm) of steel fibrous shotcrete.

Shotcrete Classics

fibers with bent or hooked ends have a high pullout resistance and are used in smaller quantities than straight fibers to achieve the same properties.

Properties

General

Properties of fiber-reinforced concrete and shotcrete are generally measured by tests advocated in ACI committee report ACI 544.2R-78.⁽¹⁾

Flexural and compressive strengths

Typical 28-day flexural strengths as determined from beam specimens vary from about 800 psi (5.5 MPa) to about 1500 psi (10.3 MPa) with the average near 1000 to 1100 psi (6.9 to 7.6 MPa).⁽⁵⁾ One flexural strength reported by the U.S. Bureau of Mines was 4617 psi (31.9 Mpa) for fibrous shotcrete and 2244 psi (15.5 MPa) for the plain, control shotcrete using regulated-set cement and 2 percent by volume of fibers.⁽⁴⁾ This was a 360 day strength. BESAB of Sweden reports flexural strengths of about 2900 psi (20 MPa) on material placed with their newly-developed wet process nozzle using fibers with an aspect ratio (l/d) of 100 at 1 percent to 2 percent by volume.

Compressive strengths at 28 days from mixes such as in Table 1 have varied from about 4200 psi to 7500 psi (29 MPa to 51.7 MPa).⁽⁵⁾ In some instances the compressive strength of the fibrous shotcrete has been lower (10 percent to 20 percent) than the control mix. This is believed due to less compaction in the shotcrete caused by the presence of the fibers. However, in many placements the compressive strength of the fibrous shotcrete has been up to 50 percent stronger than the plain control mix.

Placement of the shotcrete tends to orient the fibers in a plane parallel to the surface being shot. This orientation is of benefit to the flexural properties of the shotcrete layer.

Impact resistance

Impact resistance of steel fibrous shotcrete is measured by a test which uses a 10 lb hammer falling onto a steel ball centered on a 1½ to 2½ in. thick by 6 in. diameter specimen (38 to 63 mm thick x 150 mm dia.).⁽¹⁾ The number of blows required to crack and separate fibrous specimens at 28 days ranges from about 100 to 500 or more depending upon the fiber amount, length and configuration. Plain shotcrete specimens normally fail at from 10 to 40 blows.^(10,14)

Table 1: Typical steel fibrous shotcrete mixtures

Material	Fine aggregate mixture lb/yd ³ (kg/m ³)	3/8 in. aggregate mixture lb/yd ³ (kg/m ³)
Cement	752-940 (446-558)	750 (445)
Blended sand 1/4 in. Max. (6.35 mm)	2830-2500 (1679-1483)	1485-1175 (880-697)
3/8 in. aggr. (9.5 mm)	-	1180-1475 (700-875)
Steel fiber	66-265 (39-157)	66-250 (39-150)
Accelerator	Varies	Varies
Water:cement	0.40-0.45	0.40-0.45

Energy absorption

The amount of energy required to completely fail fibrous concrete varies with the type and amount of fiber. Typical values for small beams (4 in. x 4 in. x 14 in.) are in the range of 10 to 50 times that required for plain concrete. This is reported as toughness or as a toughness index.⁽¹⁾

Pull-out tests

Tests have been made using a pull-out anchor which is embedded in the shotcrete as it is gunned. The property measured shows a relationship to both the compressive and flexural strengths. Tests on fibrous concrete placed on a open pit mine slope in Canada gave results shown in Table 2.

Tensile strain at 90 percent ultimate load (strain-to-failure)

Kaden⁽⁷⁾ made rapid load flexural tests of shotcrete specimens (4 x 4 x 12 in. = 100 x 100 x 305 mm) and found a greatly increased strain-to-failure in the steel fibrous material. Tensile strain in the outer fibers at 90 percent of ultimate load ranged from 320 microstrain to 440 microstrain for steel fibrous shotcrete at 28 days versus 192 microstrain for plain shotcrete.

Bond strength

BESAB reports bond strengths of about 145 psi (1 MPa) to granite for steel fibrous shotcrete placed by the wet process. A bond strength of about 400 psi (2.8 MPa) was reported for in-situ tests at the Peachtree Center Station, Atlanta, Subway on a rough-surfaced granitic gneiss.⁽¹⁵⁾

Rebound considerations

General

The factors affecting rebound encompass a wide range of items and conditions. Generally, it has been noted that a greater percentage of fiber than aggregate rebound from the wall. Ryan⁽¹⁶⁾ reports fiber retention of 40 percent overhead and 65 percent on vertical surfaces. Parker⁽¹²⁾ reported fiber retention of 44 percent to 88 percent (average 62 percent) for coarse aggregate mixes, gunned onto vertical panels.

Some investigators and applicators have reported that steel fibrous mixes showed less total rebound than plain shotcrete. Others have reported no difference from the fibrous mixes.

Shotcrete Classics

An example of less rebound was reported for a trial in Nevada conducted by Fenix and Scisson, Inc. In that work, 4 yd³ of a steel fibrous mix (700 lb cement, 2700 lb sand, 150 lb 1/2 in. x 0.010 in. [12 mm x 0.25 mm] fiber per cu yd) placed six inches thick had a total estimated rebound of 10 percent. A control batch (no fiber) applied under identical conditions by the same personnel the next morning had an estimated rebound of 31 percent. The work was done in a tunnel and included vertical and overhead surfaces.

On the other hand, Parker⁽¹²⁾ reported average rebound of 18.3 percent and 17.7 percent for a non-fibrous mix and a fibrous mix, respectively, and concluded from that and other data that the mere presence of fibers in a mix does not affect rebound appreciably. Instead, other factors appeared to be more important than fiber.

Factors affecting rebound of fibers

Most of the quantitative data presently available on rebound of steel fibrous shotcrete is contained in a study by H. W. Parker⁽¹²⁾ who systematically investigated variables one at a time and made use of high-speed photography to observe and analyze the shotcrete airstream.

The high-speed photography showed that many of the steel fibers were in the outer portion of the airstream and that many of them were blown away radially from near the point of intended impact shortly before or after they hit. Some fibers were blown up into the air and floated down. It was obvious that the fibers were mostly blown away by the remnant air currents and that the effect was not one of the fibers simply bouncing off the surface. If lower air pressure or less air is used, the amount and velocity of the remnant air currents is less and the rebound of fiber is less.

Mix and shooting conditions that reduce rebound

Parker's study concluded that the rebound process differed during establishment of an initial critical thickness (Phase 1) and subsequent shooting into fresh shotcrete (Phase 2).

During Phase 1, anything that promotes adherence of material on the wall should reduce rebound. This includes the following mix conditions: a higher cement content, more fines in the mix (fly ash or very fine sand), smaller maximum size aggregate, proper wetness of aggregates so that particles are well coated with cement, and a finer gradation.

After the initial critical thickness is established, Phase 2 rebound is reduced by any condition or set of conditions that make the shotcrete on the wall softer or more plastic, at least until it tends to drop off. Thus, for maximum reduction of Phase 2 rebound, shooting as wet as possible, i.e., the wettest stable consistency, is one of the most beneficial and easiest conditions to control.

Table 2: 14-day pull-out strengths⁽⁵⁾

Mixture	Pull-out strength psi (MPa)
Plain shotcrete ^(a)	1000 (6.9)
Fibrous shotcrete ^(b)	1800 (12.4)

(a) 750 lb cement, 1825 lb 3/8 in. stone, 1175 lb sand, 5 lb Barra Gunit 2 accelerator.

(b) 750 lb cement, 1475 lb 3/8 in. stone, 1300 lb sand, 250 lb fibers 0.010 x 1/2 in. (0.25 x 13 mm), 5 lb Barra Gunit 2 accelerator.

A large number of measures can be used to reduce rebound of steel fibrous shotcrete. The most effective of these measures (which also apply to plain shotcrete) seem to be: reduction of air pressure (air velocity or amount of air at the nozzle), use of more fines and smaller aggregate, use of shorter, thicker fibers, predampening to get the right moisture content, and shooting at the wettest stable consistency.

Batching and mixing

General

Batching and mixing for the dry process is often done by mixing the dry mix, complete with fibers, in a transit mixer. This is then delivered to the hopper of the shotcrete machine. The material has also been mixed the same as normal shotcrete with the fibers being added to a mixing hopper or screw auger or in a separate air stream. Fiber feeders and special mixers are also available (see equipment). Prebagging has been found to be very useful in mines where a mixer and bulk materials would aggravate space problems. Batching and mixing of steel fibrous mixes needs some care to avoid the formation of fiber balls when preparing mixes with bulk fibers prepared and shipped as individual fibers (not collated or bundled).

Dry process

Good results were obtained in a turbine mixer (a stationary, cylindrical, flat-bottomed pan with revolving mixing arms) for Bureau of Mines tests. The sand was placed in the mixer first and the fibers were added through a 2 1/2 in. mesh screen to break up any fiber clumps. After transfer to a transit mixer and transport to a remote job site, the cement was added from sacks. A screen over the machine hopper, already a part of the equipment, was used to intercept any fiber balls that were formed.

For a larger job, the Snake River rock slope stabilization, the contractor charged the materials in 5 yd³ batches into a large hopper using a front-end loader and from there into transit mixers via a conveyor. The ingredients were added in the following order: all the sand; one-half the fibers; all the cement plus accelerator; one-half the fibers. Fibers were added through a 4 in. x 4 in. (100 mm x 100 mm) crusher screen.

Note: This technique where 500 lb of fibers were added at one time would work only for short fibers with a low aspect ratio (such as those used 1/2 in. x 0.010 in. fibers with $l/d = 50$).

Shotcrete Classics

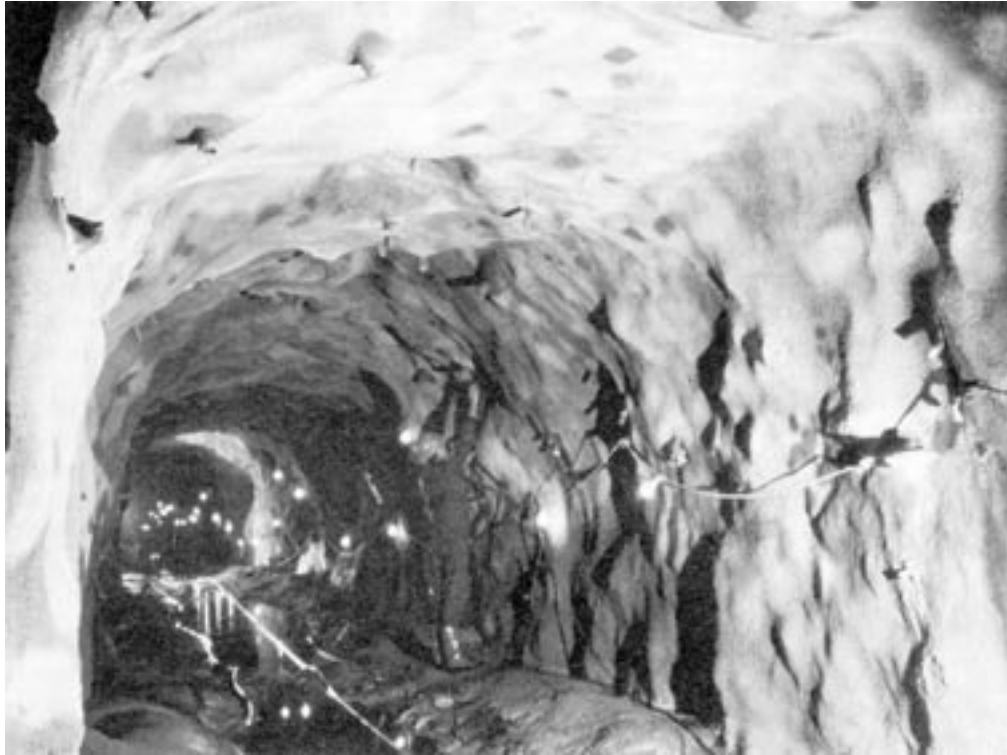

Fig. 2: Emergency coal water tunnel lining at Ringhals Nuclear Power Station, Sweden.

The important parts of the batching and mixing procedure that differ from mixing of plain shotcrete are:

- 1) The fibers should be added through a screen or by a shaker or apparatus that separates them and adds them so that they do not re-clump. This means adding them to a rotating mixer, a conveyor belt, or a screw conveyor that is carrying the fibers away fast enough so that the fibers do not stack up on each other.
- 2) Mixing should avoid kinking the fibers. Kinked fibers cause poor compaction and reduced strengths. A paddle (pugmill) mixer with small, counter-rotating paddle wheels has caused severe kinking and subsequent balling of fiber.⁽¹⁴⁾
- 3) A screen should be put over the shotcrete hopper to divert any fiber clumps.

Williamson⁽¹⁹⁾ reported that a screw-type mixer-conveyor was used along with a metering fiber feeder to mix shotcrete for spraying experimental domes at Champaign, Ill., by the U.S. Corps of Engineers. The fibers were mixed in the screw conveyor and the mix discharged directly into the gun hopper. The U.S. Bureau of Mines has also added the fibers to a screw conveyor on a rotating barrel-type shotcrete machine prior to discharging into the gun.

Collated fibers, which are bundled together with a quick-dissolving glue, do not require special handling and may be added directly to the mixer after the ag-

gregate has been added. They come apart at the nozzle in the dry mix process.

Wet process

The wet process uses a wet mix very similar to that used for cast-in-place applications. The experience there may be used to help batch and mix wet fibrous concrete for shotcreting.

There are some precautions that should be taken to prevent the formation of fiber balls during the wet mixing operation when adding non-collated fibers. The fibers should not be added too fast — that is, the mixing operation or conveyor belt should carry them away before they can pile up on each other. They should be added clump-free (through a screen or shaker screen, if necessary) and they should not be allowed to hang up or pile up on their way to or inside the mixer. A good method is to add the fibers to the fine aggregate on a conveyor belt during aggregate addition.

Where fibers are added directly to a transit mixer, a sheet metal chute extending into the drum is sometimes necessary to convey the fibers into the mixer. *The fibers should land on the mix* (not on the mixing vanes where they can form clumps). *The drum must rotate fast enough to carry away the fibers as they enter the mix* so they do not pile up on each other. The purpose of the chute is to assure that the fibers land on the mix.

Collated fibers may be added directly into a completed wet mix without causing a balling problem.

Shotcrete Classics

However, overmixing should be avoided, as too much mixing of these or of any fiber may result in fiber ball formation.

Equipment

Existing shotcrete equipment has been used to apply steel fibrous shotcrete with little or no modifications. The modifications, when made, are generally to reduce plugging by eliminating restrictions such as 90 deg. elbows or abrupt changes in hose size. If line size is reduced, a long, tapered reducer should be used. When plugging occurs, it is usually at the outlet from the gun where a sudden size reduction or change in direction is a common feature. Larger hose sizes, 2 in. (50 mm) ID and up, work better; generally, the hose diameter should be two times the fiber length. However, 1 in. fiber has been gunned through 1 in. hose, and fibrous refractories are shot regularly through 1½ in. (38 mm) hose.

Other modifications have included removing elastomeric wear linings at elbows, adding vibrators or revolving wiper arms to the hopper screen, and adding vanes in the hopper or changing wheel size on segmented rotor types to speed up material delivery. Sometimes a stronger rotor motor is needed. If no hopper screen is present, one should be added. Fig. 3 shows modifications made to a gun hopper for the Snake River rock slope stabilization project.^(5,6)

Steel fibrous shotcrete has been successfully applied with every kind of equipment, from the original single or dual chamber feed wheel type to the more recent revolving barrel and segmented rotor types. It has been placed by the wet process using a pressurized chamber type and a squeeze-pump type wet process machine. It has also been pumped as a wet mix by positive displacement pumps, another method of getting a wet mix to a nozzle.

Some special equipment has been devised to separate and meter the fibers, in a separate air stream and add them at the nozzle (both wet and dry process). This equipment enables the use of high aspect ratio fibers (up to an l/d of about 125), avoids putting the fibers through the gun, and eliminates the fiber balling problem.

Types of available equipment

Machines capable of placing steel fibrous concrete are available worldwide from a number of manufacturers. Nearly all machines are available with air, electric, or fueled engine drive. For specific details, the manufacturers should be consulted.

The specialized equipment for feeding fibers separately and adding them at the nozzle is shown in Fig. 4, 5, and 6. This feeder equipment has been modified and adopted into an integrated steel fibrous shotcrete mixing and placing system. See Fig. 7.

Applications of steel fibrous shotcrete

Applications of steel fibrous shotcrete have been made to rock slopes, mines, tunnels, dams, and numerous other locations.



Fig. 3: Modified gun hopper with screen, revolving arms, and pneumatic vibrator.

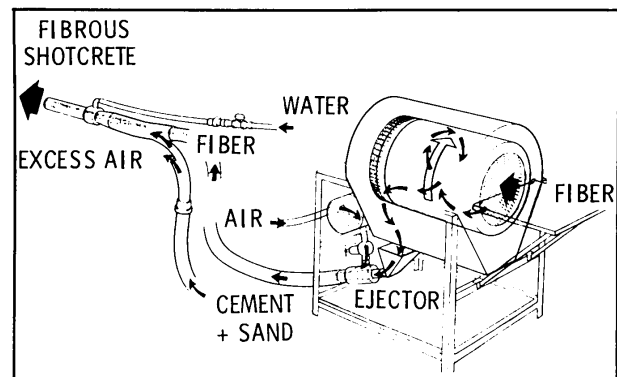

Fig. 4: Original BESAB fiber feeder. (Ref. 17, p. 53)

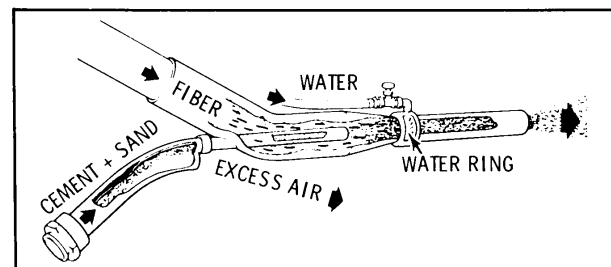

Fig. 5: Original BESAB nozzle for dry process fibrous shotcrete. (Ref. 17, p. 55)

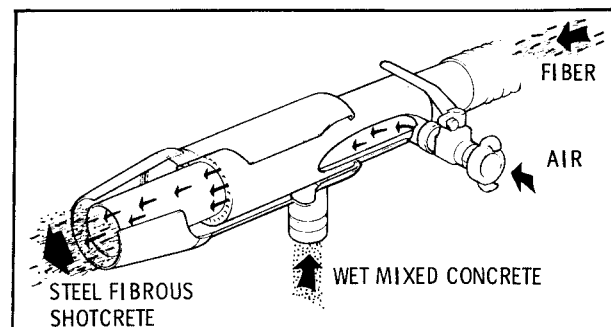

Fig. 6: BESAB nozzle for wet process fibrous shotcrete.

Shotcrete Classics

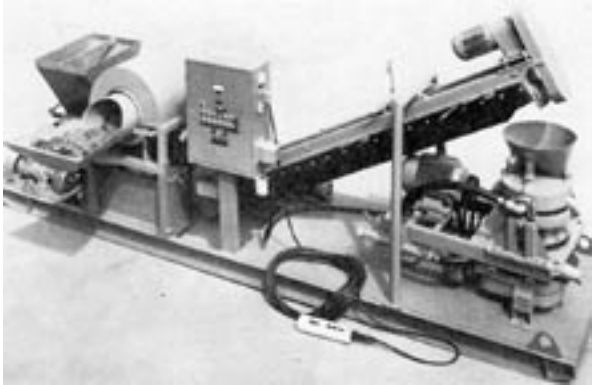

Fig. 7: Integrated fiber feeder, mixer, and gun for steel fibrous shotcrete. (Photo courtesy Allentown Pneumatic Gun Co.)

Slope stabilization

Corps of Engineers — Snake River Rock Slope Stabilization^(6,7)

A large application of steel fibrous shotcrete was completed in January 1974, near Little Goose Dam along the Snake River in the State of Washington. The shotcrete was used to stabilize a deteriorating section of rock slope above the Camas Prairie Railroad. The work included scaling, installation of rock bolts, and application of shotcrete a minimum of 2½ in. thick (63 mm). The area involved was about 1550 ft (460 m) long and varied from 15 to 45 ft (5 to 14 m) high for a total of 6900 sq yd (5800 m²).

The mixes used 0.010 in. x ½ in. (0.25 mm x 13 mm) steel fibers; the amount of fiber varied from 200 to 250 lb/yd³ (119 to 148 kg/m³) and the cement content varied from 752 to 940 lb/yd³ (445 to 558 kg/m³). Rebound ranged from 13 percent to 16 percent. The use of steel fibrous shotcrete saved \$50,000 over the alternate construction method of using conventional shotcrete over wire mesh. The total contract cost including rock scaling and rock bolts was \$264,000.

Joint Nordic Program (Nordforsk) — Oil Refinery — Brofjorden, Sweden

A large application was also made at an oil refinery at Brofjorden, on the west coast of Sweden (Fig. 8). About 4500 m² (5380 yd²) of rock surface was stabilized using 0.7 percent by volume of 0.4 x 25 mm (0.016 x 1.0 in.) fibers in a dry mix. A layered construction was used: 0.5 to 1 cm (0.2 to 0.4 in.) of plain shotcrete followed by 3 cm (1-3/8 in.) of steel fibrous shotcrete covered with a top layer of 0.5 to 1 cm of plain shotcrete.

Selected underground applications

Corps of Engineers, Ririe Dam, Tunnel Adit, Idaho⁽⁷⁾

In December 1972, steel fibrous shotcrete was used to line a 40 ft length of an exploratory tunnel adit on the right abutment of Ririe Dam, Idaho. The fibers were 0.016 x ¾ in. (0.4 x 19 mm). Type II ce-



Fig. 8: Portion of rock surface stabilized at Brofjorden Refinery, Sweden.

ment was used and proportioned at 940 lb/yd³ (558 kg/m³). Approximately 85 yd² of surface were covered. Thickness was 3 in. (75 mm) and the 34 day flexural strength of cast beams was 910 psi. The lining survived a blasting operation with minor cracking.

U.S. Bureau of Mines — Coal Mine Applications

Underground rooms at the USBM's experimental mine at Bruceton, Pa., were enlarged, rock bolted and sprayed with steel fibrous shotcrete.⁽³⁾ Approximately 4 in. (100 mm) was applied to the ribs and 8 in. (200 mm) to the roof using 1 x 0.010 x 0.022 in. (25 x 0.25 x 0.56 mm) fibers in the amount of 2 percent by weight (about 80 lb/yd³, 47 kg/m³). Fibrous concrete was also used to coat bulkheads, seals, and stoppings formed of Bernold Steel.⁽¹⁾ It has been shown by testing to provide good fireproofing protection for urethane foam.⁽⁸⁾

Bolidens Gruv AB - Mines and Ore Shaft, Sweden

Fibrous shotcrete has been used in a number of mines in Sweden. At the Bolidens Gruv AB mine near Kristineberg, the material was used to line and stabilize a gravity ore transfer shaft which was deteriorating from the impact of the ore. The shaft was filled with ore and then gradually lowered. The top surface of the ore became the working platform for the shotcreting operation (Fig. 9). The mix used one part cement to three parts sand of 8 mm (5/16 in.) maximum size containing 1.4 volume percent of 0.25 x 25 mm (0.010 x 1 in.) long deformed fibers. The total rebound was about 15 percent. The thickness varied from 10 to 50 cm (4.0 to 20 in.).

British Rail — Arch and Tunnel Relining, England

Shotcrete with 3 percent by weight of 0.4 x 25 mm (0.016 x 1 in.) long deformed fibers has been used in lieu of mesh reinforced shotcrete for strengthening tunnels and brick arches under bridges for British Rail in England. One advantage in rail tunnels is that because steel mesh is not used, scaffolding is not required and traffic does not have to be interrupted. It is applied up to 6 in. (150 mm)

Shotcrete Classics

thick. A 1/2 in. (13 mm) flash coat is used to cover exposed fibers.

A total of 5 tunnels in the Liverpool/Birmingham area and three bridges near Birmingham and Leicester were sprayed. A mix of 1:4 with 10 mm (0.4 in.) maximum size aggregate was used. (Fig. 1).

Swedish State Power Board — Ringhals Nuclear Power Station

An emergency cold water tunnel at the Ringhals Nuclear Power Station in Sweden was lined with steel fibrous shotcrete using the wet process equipment. Rock bolts were used and wire mesh was eliminated (Fig. 2).

Roadway Tunnels — Japan

The Japanese have used steel fibrous shotcrete in at least three vehicular tunnels. In the Miyanoshta tunnel it was used to repair concrete lining damaged by rock pressure. In the Itaya tunnel, it was placed 4 in. (100 mm) thick to repair the original, 50 year old lining which had deteriorated from icing conditions. In a tunnel near Hakodate, Hokkaido, it was placed as a trial lining. All of these applications used the wet process and a squeeze-type pump.

Other applications

Other steel fibrous shotcrete applications have included lining of an oil storage cavern at Skarvik, Sweden, using the wet process; residences of sandwich wall construction at Rainworth, England; in-

flation/foam/shotcrete shelters at Champaign, Illinois"; lighthouse and chimney repairs in Sweden; resurfacing of a rocket flame deflector at Cape Canaveral, Florida; coal mine strengthening and sealing of stoppings by National Coal Board, England; stabilization of the Tuve landslide in Sweden; and forming boat hulls similar to ferrocement, using fibers alone and fibers plus mesh.

Presented at the Shotcrete Symposium, ACI fall convention, Washington, D.C., Nov. 1, 1979, and reviewed under Institute publication policies.

References

1. ACI Committee 544, "Measurement of Properties of Fiber Reinforced Concrete," (ACI 544.2R-78), ACI JOURNAL, *Proceedings*, V. 75, No. 7, July 1978, pp. 283-289.
2. *Shotcrete for Ground Support*, SP-54, American Society of Civil Engineers/American Concrete Institute, Detroit, 1977, 766 pp.
3. Chronis, N. P., "Three Innovations in Mine Expansion Tested at Bruceton Experimental Mine," *Coal Age*, Apr. 1975.
4. Henager, C. H., "A New Wrinkle — Shotcrete Containing Steel Fibers," *Concrete Construction*, V. 20, No. 8, Aug. 1975, pp. 345-347.
5. Henager, C. H., "The Technology and Uses of Steel Fibrous Shotcrete: A State-of-the-Art Report," Battelle-Northwest, Richland, Sept. 1977, 60 pp.

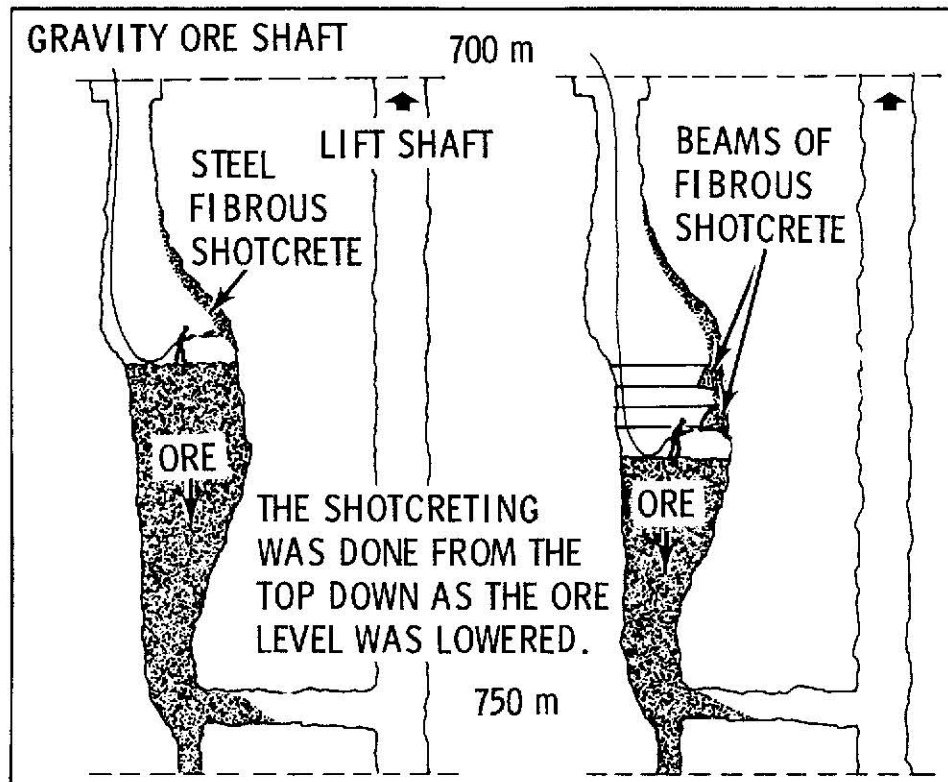

Fig. 9: Technique for lining of ore shaft at Bolidens Mine, Sweden. (Ref. 17, p. 73)

Shotcrete Classics

6. Kaden, R. A., "Slope Stabilized With Steel Fibrous Shotcrete," *Western Construction*, Apr. 1974, pp. 30-33.

7. Kaden, Richard A., "Fiber-Reinforced Shotcrete Ririe Dam and Little Goose (CPRR) Relocation," *Shotcrete for Ground Support*, SP-54, American Society of Civil Engineers/American Concrete Institute, Detroit, 1977, pp. 66-88.

8. Lankard, D. R., "Field Experiences With Steel Fibrous Concrete," American Ceramic Society Meeting, Chicago, Apr. 26, 1971.

9. Mahar, J. W.; Parker, H. W.; and Wuellner, W. W., "Shotcrete Practice in Underground Construction," *Report No. FRA-OR&D 75-90*, Federal Railroad Administration, Washington, D.C. Aug. 1975, 482 pp.

10. Morgan, D. R., "Steel Fiber Shotcrete — A Laboratory Study," *Concrete International: Design and Construction*, V. 3, No. 1, Jan. 1981, pp. 70-74

11. Murphy, E. M., "Steel Fiber Shotcrete in Mines," *Concrete Construction*, V. 20, No. 10, Oct. 1975, pp. 443-445.

12. Parker, H. W.; Fernandez, G.; and Lorig, L. J., "Field-Oriented Investigation of Conventional and Experimental Shotcrete for Tunnels," *Report No. FRA-OR&D 76-06*, Federal Railroad Administration, Washington, D.C., Aug. 1975.

13. Poad, M. E.; Serousek, M. O.; and Goris, J., "Engineering Properties of Fiber-Reinforced and Polymer-Imregnated Shotcrete," *Report of Investigations No. 8001*, U.S. Bureau of Mines, Washington, D.C., 1975, 25 pp.

14. Ramakrishnan, V., et al., "A Comparative Evaluation of

Fiber Shotcrete," *Report No. SDSM&T-CBS 7902*, South Dakota School of Mines & Technology, Rapid City, Aug. 1979.

15. Rose, D. C., et al., "The Atlanta Research Chamber, Applied Research for Tunnels," *Interim Report No. UMTA-GA-0007-79-1*, U.S. Department of Transportation, Washington, D.C., June 1979.

16. Ryan, T. F., "Steel Fibers in Gunite, An Appraisal," *Tunnels and Tunnelling* (London), July 1975, pp. 74-75.

17. Sandell, Bertil, "Stalfiberarmerad Sprubetong," *Proceedings, "Informations — Dagen 1977,"* Cement-Och Betonginstitutet, Stockholm, Mar. 15, 1977.

18. Warner, B. L., "Evaluation of Materials for Protecting Existing Urethane Foam in Mines," *Report No. OFR 75-76* (NTIS PB 254 682), U.S. Bureau of Mines, Washington, D.C., Sept. 1974.

19. Williamson, G. R., et al., "Inflation/Foam/Shotcrete System for Rapid Shelter Construction," *CERL Technical Report No. M-215*, U.S. Army Construction Engineering Research Laboratory, Champaign, May 1977.



Charles H. Henager, now retired, was a civil engineer employed by Battelle Pacific Northwest Laboratories, Richland WA, for most of his career. He graduated from Washington State University in 1950. He was active in the ACI International Committee 544, Fiber Reinforced Concrete and 506, Shotcreting.